

TOX®  PRESSOTECHNIK

TOX®-Tongs

Robot Tongs / Machine Tongs / Handheld Tongs

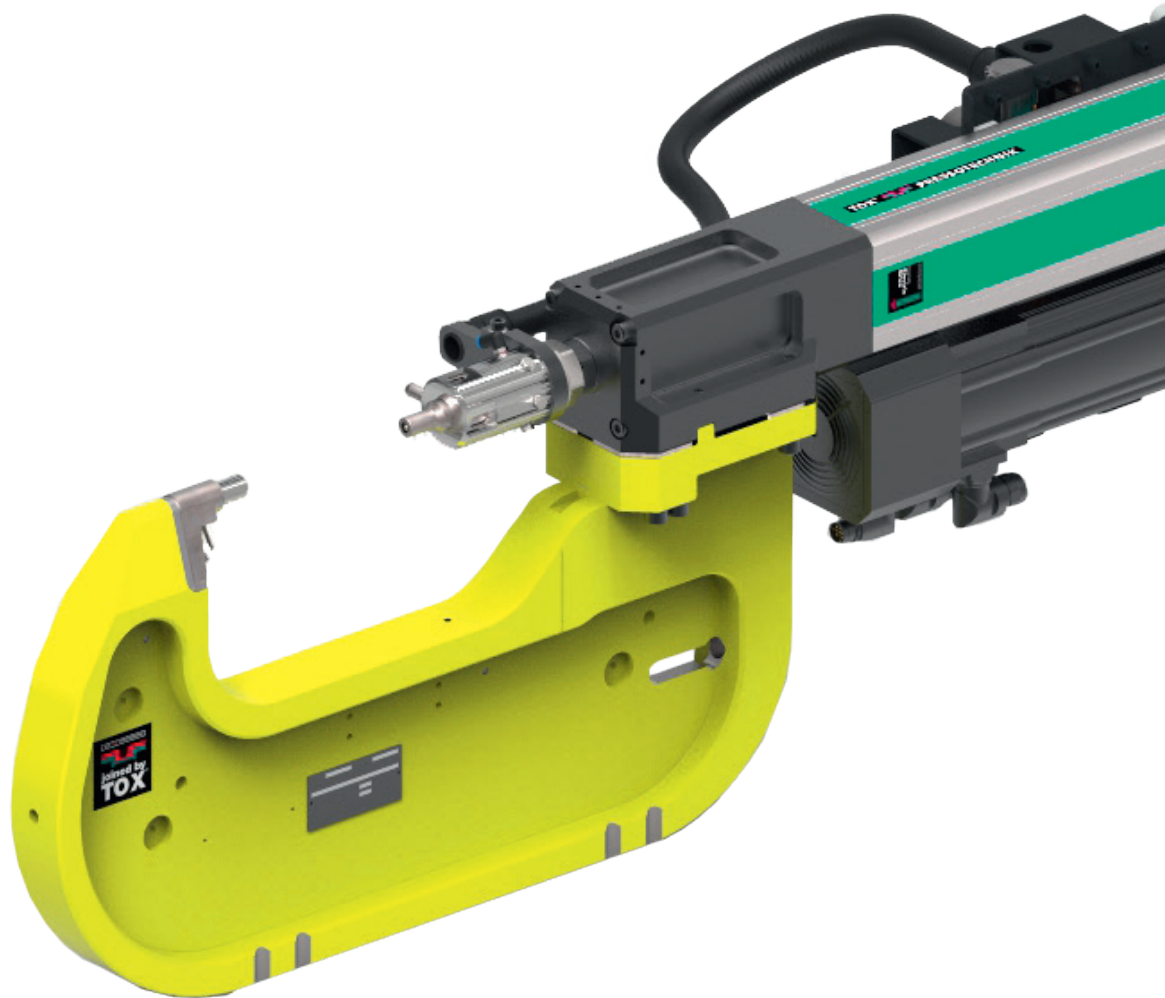

TOX[®]-Tongs modular system

Clinching, punching, assembly, marking – the modular TOX[®] system provides a unique solution for each of these applications. Depending on customer requirements, frames, tools and drives can be specifically combined with controls and monitoring to create a solution. The use of standard components ensures the high quality standard of our systems. In addition to the application part, the handling required decides whether robot, machine or handheld tongs are used.

To select the appropriate system for your application we consider all requirements including force, stroke, part geometry and control and monitoring needs. Our team will be pleased to discuss the systems preselected by you and will provide comprehensive advice.

2 Bow

- C-bow for robot application
- Compact version for machine integration
- Miniature version for handheld tongs

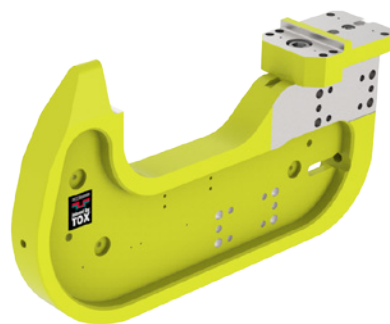

1 Tools



Clinching tools



Setting head riveting/
functional elements



Punching tool



Marking tool

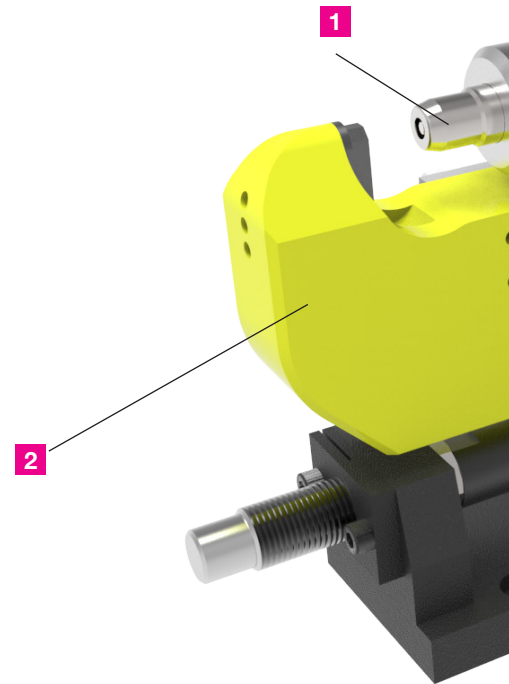

Possible applications



Clinching, TOX[®]-
Sheet Metal Joining



Riveting

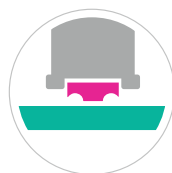

Pressing-in,
insertion of
functional
elements

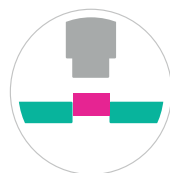

Assembling,
press-fitting



Punching, piercing



Coining, marking

3 Drives

- Efficient and precise with the electromechanical TOX®-ElectricDrive
- Energy-saving and powerful with the pneumo-hydraulic TOX®-Powerpackage
- Compact TOX®-Hydraulic Cylinder with external pressure intensifier
- Pneumatic drive for low press forces

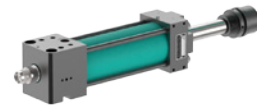
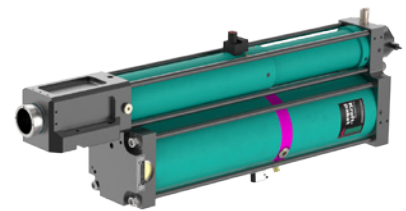
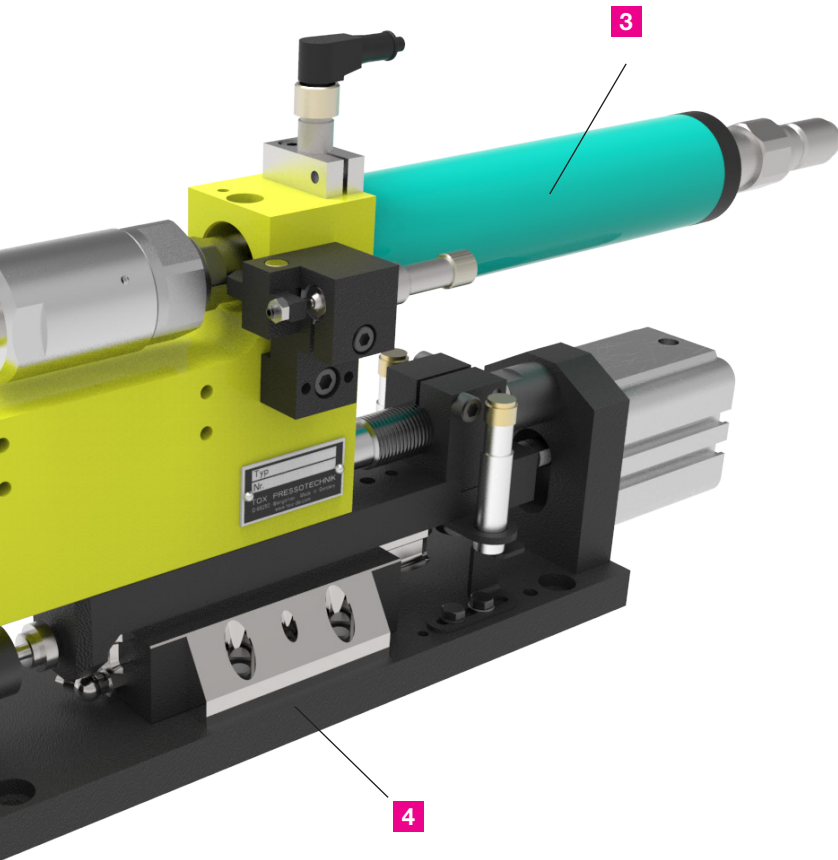

4 Installation accessories

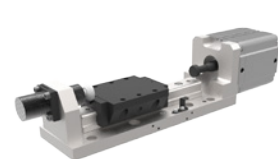

Compensating slide



Robot consoles



Equalizing for drive with die

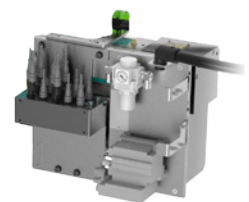

Tongs installation plate

TOX[®]-Robot Tongs, TOX[®]-Machine Tongs

TOX[®]-Tongs are perfectly suited for integration into automated production environments. The tongs can be mounted to the robot arm (robot tongs) or in a production line station (machine tongs) via the console. Each application is defined by the tool, drive and application-specific control and monitoring.

TOX[®]-Robot Tongs are designed for high productivity in production lines and robot cells.

- Components from the modular TOX[®] system
- Completely ready for connection
- Robot-controlled or stationary
- Tool opening: up to 95 mm
- Press force: 50 kN to 80 kN
- Throat depth: up to 450 mm

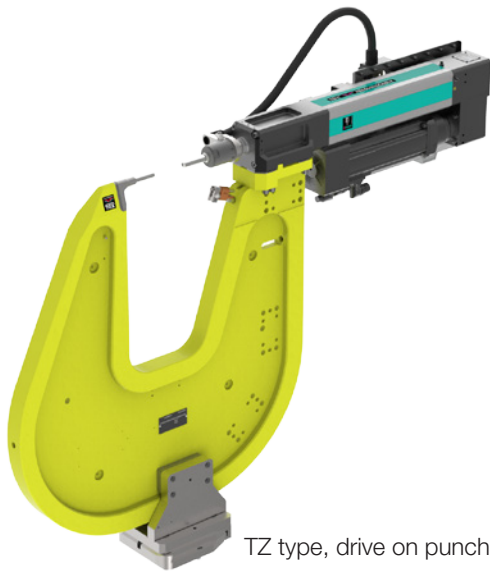

TZ type, drive on punch side

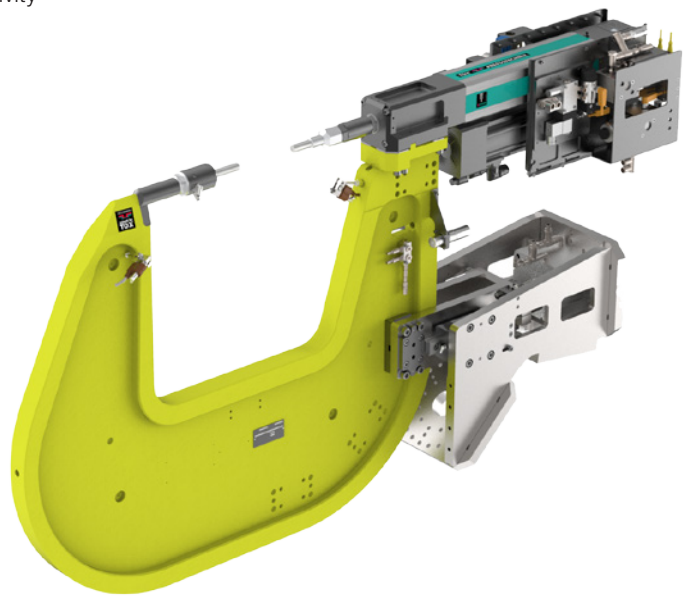

TZ type with equalizing, drive on die side

The **TOX[®]-Machine Tongs CMH 03** are suitable for stationary operation and can be easily integrated into systems due to its compact dimensions.

- Compact dimensions
- Stationary application in machines
- Tool opening: up to 18 mm
- Press force: 45 kN to 75 kN
- Throat depth: up to 100 mm

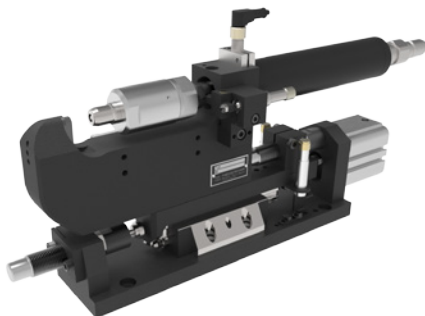

The **TOX[®]-PowerKurver KKG 90** has a purely pneumatic drive. The special cam track ensures a fast approach stroke and a high press force.

- Constant force-travel-characteristic in the working area
- Excellent accessibility
- Opening angle: up to 90°
- Press force: up to 90 kN
- Throat depth: up to 300 mm

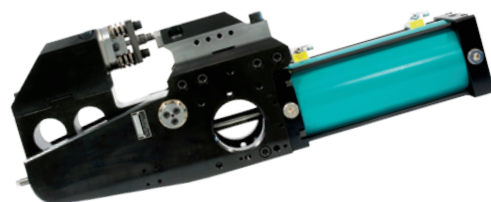

TOX®-Handheld Tongs

The TOX®-Handheld Tongs with their compact dimensions are suited to all areas of the sheet metal joining technology. They are robust, durable and optimized for simple handling.

TOX®-Handheld Tongs are available with different mounting brackets and rotary manifold connections.

Also for mobile applications: The **TOX®-Mini-Handheld Tongs** in C-bow design are driven by a pneumohydraulic intensifier.



For mobile or stationary operation:

CMH 03.45

- Hydraulically driven C-frame tongs
- Tool opening: up to 6 mm for 1-hand operation
- Tool opening: up to 30 mm for 2-hand operation
- Press force: 45 kN at 470 bar oil pressure
- Throat depth: up to 100 mm

Ideal for clinching applications: The version and design of **TOX®-Mini Tongs** can be configured to your application.



CMH 04.45

- Tool opening: up to 6 mm
- Press force: 45 kN at 470 bar oil pressure
- Throat depth: up to 37 mm



CHH 03.45 / CHH 03.75 can also be installed as machine tongs

- Versatile C-bow designs
- Tool opening: up to 6 mm with 1-hand operation
- Tool opening: up to 50 mm for 2-hand operation
- Press force: 45 kN / 75 kN at 250 bar oil pressure
- Throat depth: 60 mm



Our specialist for air duct assembly: Flap tongs

CMH 01.45

- Rotation 360°
- Tool opening: up to 6 mm
- Press force: 45 kN at 6 bar air pressure
- Throat depth: up to 50 mm



CHH 04.45 with hydraulic drive

- Tool opening: up to 6 mm with 1-hand operation
- Tool opening: up to 30 mm for 2-hand operation
- Press force: 45 kN at 250 bar oil pressure
- Throat depth: up to 35 mm



Connects smallest flanges: **CMH 02.30**

- Internal supply connections
- Tool opening: up to 6 mm
- Press force: 30 kN at 6 bar air pressure
- Throat depth: up to 8 mm

Accessories and options

TOX®-Controls are a safe process control whether using the pneumatic base version, the electropneumatic version or the programmable logic controller. In addition, **TOX®-Monitoring** is a seamless quality check of pressing processes. Integrated into common bus systems, the systems provide important information about the process sequence. The TOX®softWare combines control, monitoring and analysis. Its interactive work environment for all applications provides a quick project overview.

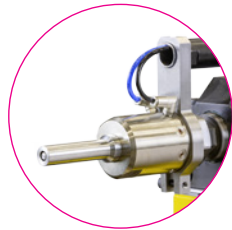

The die monitoring **TOX®-ToolCheck** pneumatically monitors the condition of the TOX®-Clinching Dies. It is either integrated into the tongs or mounted stationary within the reach of the robot. Missing or displaced segments due to contamination or breaks in rigid or solid die segments are detected in less than a second.

The modular **TOX®-Spray System** accurately sprays piecepart surfaces and/or tools before the joining process. This reduces joining and stripping forces, while allowing better forming of the materials. It is mounted to the tongs or in the tool.

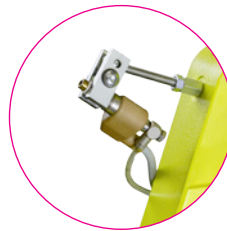

The external **TOX®-Pressure Intensifier** boosts the connected air pressure from 6 bar to the required oil pressure of 250 or 470 bar. Depending on the application, the intensifier can be mounted in any orientation when stationary or horizontally on a carriage.

Consoles and compensating slides ensure a stable guiding of the tongs. They balance the tool weight and compensate for tolerances.



For controlling the robot tongs, the **tongs installation plate ZIP** has the required bus modules, valves and sensors as well as electrical and pneumatic interfaces.

Sample applications

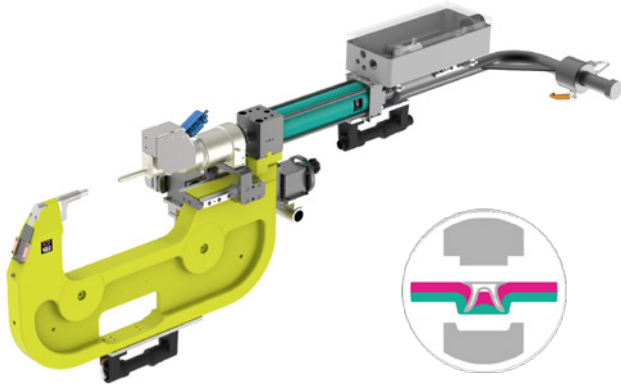

Riveting tongs with TOX®-Hydraulic Cylinder

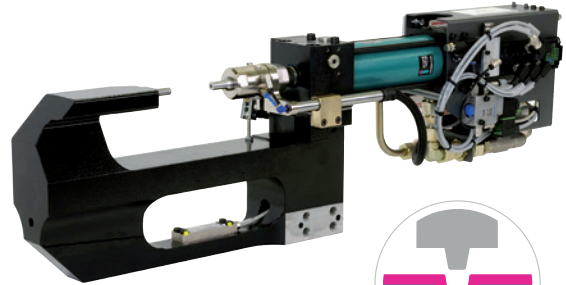

Machine tongs with TOX®-Hydraulic Cylinder

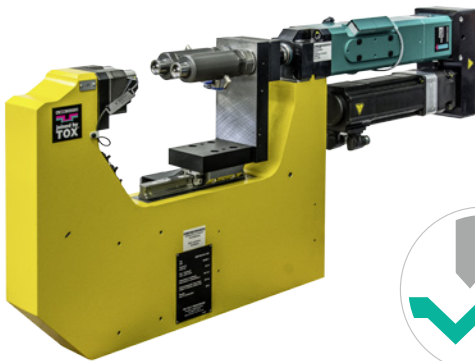

Machine tongs with TOX®-ElectricDrive

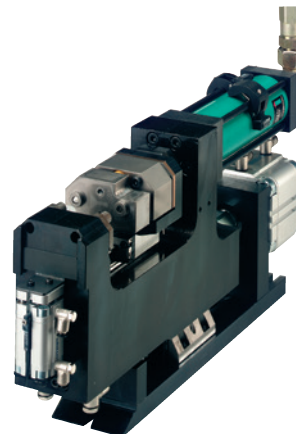

Punching tongs with TOX®-Hydraulic Cylinder



Punching tongs with pneumatic cylinder



Flange tongs with TOX®-Mini Hydraulic Cylinder

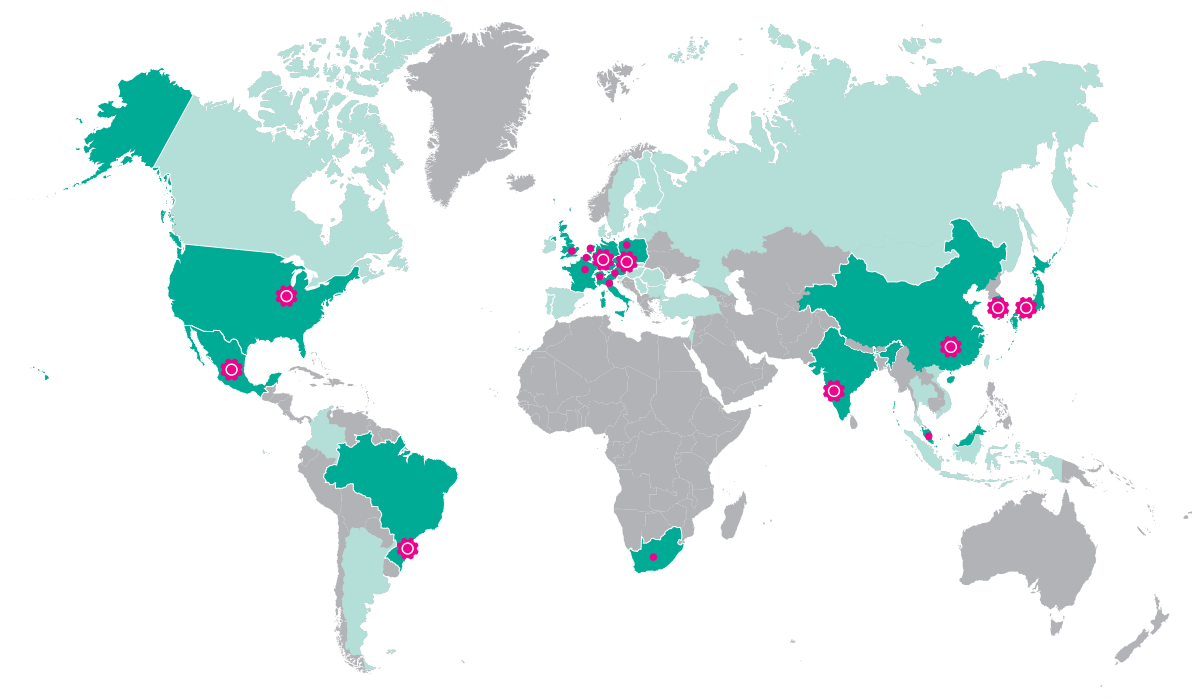

TOX®  PRESSOTECHNIK

TOX® PRESSOTECHNIK GmbH & Co. KG
Riedstrasse 4
88250 Weingarten / Germany

TOX® PRESSOTECHNIK L.L.C.
4250 Weaver Parkway
Warrenville, IL 60555 (USA)

Find your local contact at:
tox-pressotechnik.com

90.201905.us Subject to technical modifications.